

Couplings & Trailer Support

Couplings for braked & unbraked trailers • Jockey wheels • Propstands



Contents	Page
Unbraked couplings including dedicated coupling locks, up to 750KG GVW	13
Knott KF13 & KFG13 hydraulically damped overrun couplings 750-1400Kg GVW	14
Knott KFG27 hydraulically damped overrun couplings 1400-2700Kg GVW	15
Knott KFG35 hydraulically damped overrun couplings 2700-3500Kg GVW	16
Knott KRV20 hydraulically damped overrun couplings 1100-2000Kg GVW	17
Propstands (tubular), jockey wheels, jockey spares, clamps and brackets	18
Bolt on propstands and spigots for the LT/LM, beavertail or tilt-bed trailer ranges	19
Al-Ko 251s coupling hydraulically damped overrun couplings 1500-2600Kg GVW	20

1	P00355	Coupling unit. 750kg GVW 50mm ball, pressed steel coupling head for fitting to 50mm square tube drawbars (unbraked trailers). £16.45
2	P0150	Coupling unit. 750kg GVW 50mm ball, cast iron coupling head for surface mounting (unbraked trailers). £25.00
3	P00366	Hitch lock. Fits over the groove on the P6e (Knott) and older Al-Ko coupling heads blocking access to the ball. £19.00
4	P00354*	Slider lock. Fits within the sliding bolt aperture on the P00355 head to prevent operation of the handle, can also be used when coupled to car. £4.70
5	P00368	Barrel lock (Bradley). Fits into a hole in P0150 coupling heads preventing operation of the handle. £12.00
	P00355SC	Secondary coupling cable. Used with P00355 unbraked coupling head. £3.53

* Visual deterrent only



See page 106 for other security products including locks for our braked couplings

To Order – See pages 4 & 5 for distributor contact details or call direct on 0845 4082 505



To Order – See pages 4 & 5 for distributor contact details or call direct on 0845 4082 505

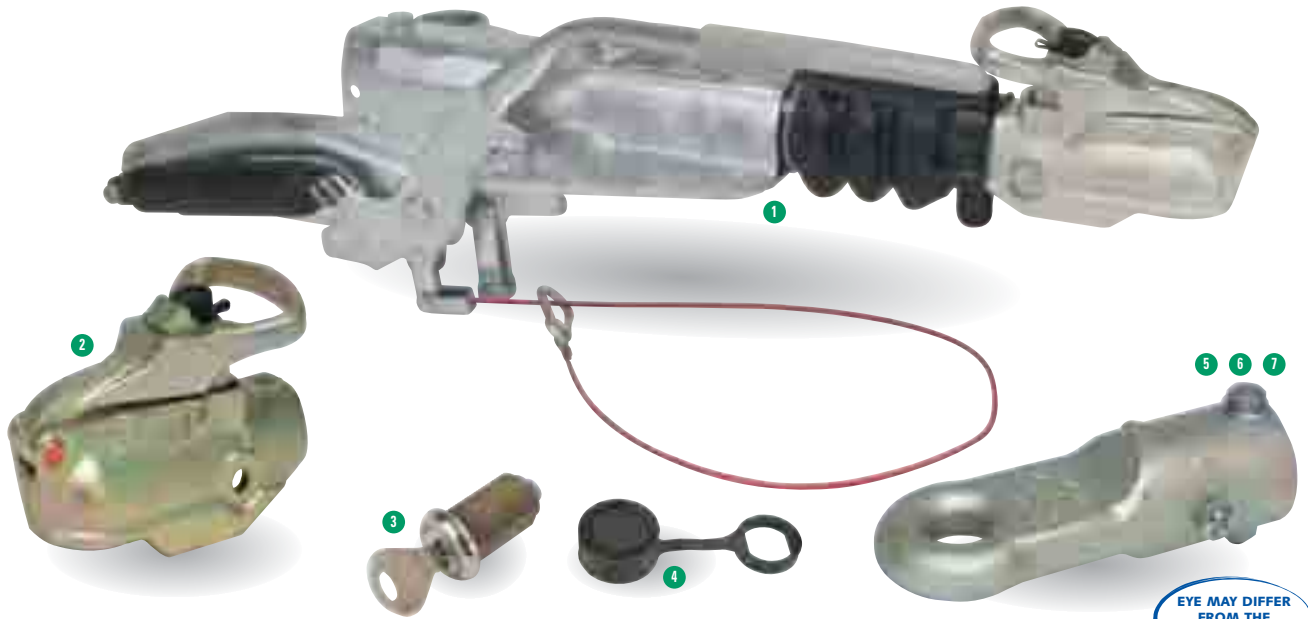

EYE MAY DIFFER FROM THE PHOTOGRAPH

1	P00317 KF13 Coupling unit (pressed steel body). 750-1400kg GVW Hydraulically damped overrun coupling unit, incorporating energy store handbrake for use with autoreverse brakes and 50mm ball hitch. £155.10
	P00327 KFG13 Coupling unit (cast body). 750-1400kg GVW Hydraulically damped overrun coupling unit, incorporating energy store handbrake for use with autoreverse brakes and 50mm ball hitch. £198.80
2	P00301 Coupling head. Replacement low-profile head for KF/KFG overrun units with a 50mm drawtube with lock. £47.00
3	P00302 Lock insert. Replacement lock for the Avonride coupling head. £17.65
4	P00303 Cover cap. Protects the P00301 Avonride coupling head lock from ingress of dust and water. £1.60
5	P00318C 30mm Eye. Eye kit includes all mounting hardware to fit KF13 overrun unit. £41.15
6	P00333 40mm Eye. Eye kit includes all mounting hardware to fit KF13 overrun unit. £41.15
7	P00376 Nato Eye. Towed by Nato style towing jaw, can be fitted to the KFG13 in place of the existing eye or head. £95.00
8	P00369 Bellows. Replacement protective bellows for drawtube of KF/KFG-13 and KRV20 overrun units. £6.50
9	P00937 Damper. Replacement hydraulic damper for KF13. £25.00
	P00936 Damper bracket. Holds one end of the damper rod within the body of the KF13 overrun unit. £5.00
10	P00938 Drawtube. For the KF13 overrun unit, includes stop ring. £30.00
11	P00931 Powered handbrake upgrade kit. Complete with oil-damped spring pack, handbrake lever and all mounting hardware etc. £32.00
	P00868 Spring Pack. Oil-damped unit only, as fitted to later or upgraded units. £18.51
12	P00940 Overrun lever. Fitted to the rear of the coupling unit, this lever creates the pull on the brake rod. £11.00
13	P00363 Clamp handle. Long jockey clamp handle for Knott couplings. £3.50
	P00399 Retainer pad. Fits within the recess in the overrun unit to securely clamp the jockey wheel. £4.50
15	P00387 Breakaway cable spring ring type. It is recommended that you carry a spare breakaway cable whenever you tow. £5.90
16	P00899 Breakaway cable clevis type. For more recent knott couplings having this type of cable fitted originally. £5.90
	P00939 Packing Shim. Fits under the coupling head P00301. £2.50





EYE MAY DIFFER FROM THE PHOTOGRAPH

- 1 P00335 **KFG27 Coupling unit (cast body).** 1400-2700kg GVW Hydraulically damped overrun coupling unit, incorporating energy store handbrake for use with autoreverse brakes and 50mm ball hitch. **£164.50**
- 2 P00301 **Coupling head.** Replacement lockable low-profile head for KF/KFG overrun units with a 50mm drawtube. **£47.00**
- 3 P00302 **Lock insert.** Replacement lock for the Avonride coupling head. **£17.65**
- 4 P00303 **Cover cap.** Protects the Avonride coupling head lock from ingress of dust and water. **£1.60**
- 5 P00404 **30mm Eye.** Eye kit includes all mounting hardware to fit KFG27 overrun unit. **£41.15**
- 6 P00339 **40mm Eye.** Eye kit includes all mounting hardware to fit KFG27 overrun unit. **£41.15**
- P00420 **50.8mm Eye kit.** Eye kit includes all mounting hardware to fit KFG27 overrun unit. **£47.00**
- 7 P00376A **Nato Eye.** Eye kit includes all mounting hardware to fit KFG27 overrun unit. **£95.00**
- 8 P00369 **Bellows.** Replacement protective bellows for drawtube of KF27 (Pressed steel body). **£6.50**
- 9 P00417 **Bellows.** Replacement protective bellows for drawtube of KFG27 overrun unit (Cast body). **£6.50**
- 10 P00374 **Damper.** Replacement hydraulic damper for KFG27. **£29.40**
- P00878 **Damper support bracket.** Fits within body of coupling. **£5.20**
- P00882 **Grease nipple adaptor.** Bolt that is fitted through handle. **£2.94**
- 11 P00408 **Drawtube.** 50 x 10 DIN2391. **£35.00**
- 12 P00951 **Powered handbrake upgrade kit.** Complete with oil-damped spring pack, handbrake lever and all mounting hardware etc. **£44.05**
- P00868 **Spring Pack.** Oil-damped unit only, as fitted to later or upgraded units. **£18.51**
- 13 P00413 **Overrun lever.** Fitted to the rear of the coupling unit, this lever creates the pull on the brake rod. **£11.00**
- 14 P00363 **Clamp handle.** Long jockey clamp handle for Knott couplings. **£3.50**
- 15 P00399 **Retainer pad.** Fits within the recess in the overrun unit to securely clamp the jockey wheel. **£4.50**
- 16 P00387 **Breakaway cable spring ring type.** It is recommended that you carry a spare breakaway cable whenever you tow. **£5.90**
- 17 P00899 **Breakaway cable clevis type.** For more recent knott couplings having this type of cable fitted originally. **£5.90**
- 18 P00915 **Manual reverse.** For KFG27 Overrun units. While the basic reversing function remains automatic, this kit allows easier reversing up steep hills or on poor surfaces, where traction can sometimes be a problem. **£12.00**

To Order – See pages 4 & 5 for distributor contact details or call direct on 0845 4082 505

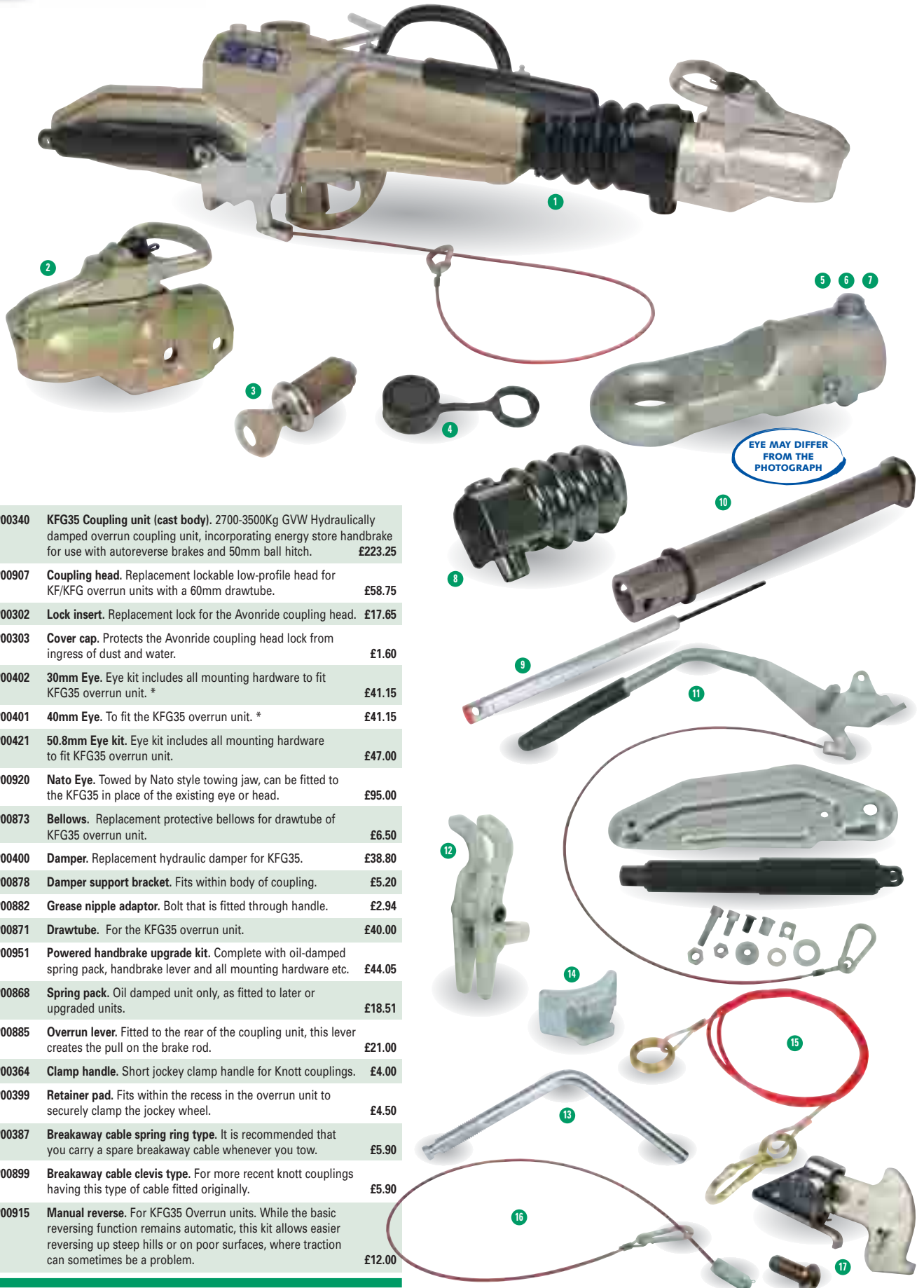

EYE MAY DIFFER FROM THE PHOTOGRAPH

- | | | | |
|----|---------------|---|---------|
| 1 | P00340 | KFG35 Coupling unit (cast body). 2700-3500Kg GVW Hydraulically damped overrun coupling unit, incorporating energy store handbrake for use with autoreverse brakes and 50mm ball hitch. | £223.25 |
| 2 | P00907 | Coupling head. Replacement lockable low-profile head for KF/KFG overrun units with a 60mm drawtube. | £58.75 |
| 3 | P00302 | Lock insert. Replacement lock for the Avonride coupling head. | £17.65 |
| 4 | P00303 | Cover cap. Protects the Avonride coupling head lock from ingress of dust and water. | £1.60 |
| 5 | P00402 | 30mm Eye. Eye kit includes all mounting hardware to fit KFG35 overrun unit. * | £41.15 |
| 6 | P00401 | 40mm Eye. To fit the KFG35 overrun unit. * | £41.15 |
| | P00421 | 50.8mm Eye kit. Eye kit includes all mounting hardware to fit KFG35 overrun unit. | £47.00 |
| 7 | P00920 | Nato Eye. Towed by Nato style towing jaw, can be fitted to the KFG35 in place of the existing eye or head. | £95.00 |
| 8 | P00873 | Bellows. Replacement protective bellows for drawtube of KFG35 overrun unit. | £6.50 |
| 9 | P00400 | Damper. Replacement hydraulic damper for KFG35. | £38.80 |
| | P00878 | Damper support bracket. Fits within body of coupling. | £5.20 |
| | P00882 | Grease nipple adaptor. Bolt that is fitted through handle. | £2.94 |
| 10 | P00871 | Drawtube. For the KFG35 overrun unit. | £40.00 |
| 11 | P00951 | Powered handbrake upgrade kit. Complete with oil-damped spring pack, handbrake lever and all mounting hardware etc. | £44.05 |
| | P00868 | Spring pack. Oil damped unit only, as fitted to later or upgraded units. | £18.51 |
| 12 | P00885 | Overrun lever. Fitted to the rear of the coupling unit, this lever creates the pull on the brake rod. | £21.00 |
| 13 | P00364 | Clamp handle. Short jockey clamp handle for Knott couplings. | £4.00 |
| 14 | P00399 | Retainer pad. Fits within the recess in the overrun unit to securely clamp the jockey wheel. | £4.50 |
| 15 | P00387 | Breakaway cable spring ring type. It is recommended that you carry a spare breakaway cable whenever you tow. | £5.90 |
| 16 | P00899 | Breakaway cable clevis type. For more recent knott couplings having this type of cable fitted originally. | £5.90 |
| 17 | P00915 | Manual reverse. For KFG35 Overrun units. While the basic reversing function remains automatic, this kit allows easier reversing up steep hills or on poor surfaces, where traction can sometimes be a problem. | £12.00 |

* Bellows included with this part

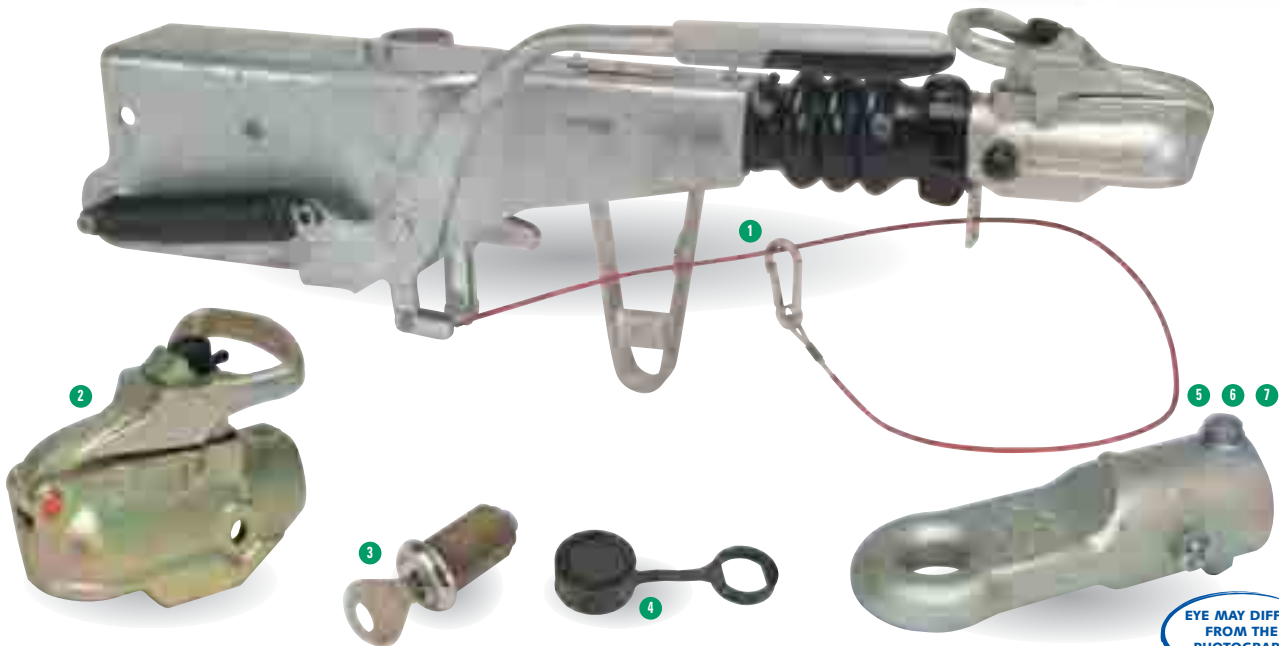

EYE MAY DIFFER FROM THE PHOTOGRAPH

- 1 P00320 **KRV20 Coupling unit (pressed steel body) for 100mm square tube drawbars.** 1100-2000Kg GVW Hydraulically damped overrun coupling unit, incorporating energy store handbrake for use with autoreverse brakes and 50mm ball hitch. **£145.70**
- 2 P00301 **Coupling head.** Replacement lockable low-profile head for KF/KFG overrun units with a 50mm drawtube. **£47.00**
- 3 P00302 **Lock insert.** Replacement lock for the Avonride coupling head. **£17.65**
- 4 P00303 **Cover cap.** Protects the Avonride coupling head lock from ingress of dust and water. **£1.60**
- 5 P00318C **30mm Eye.** Eye kit includes all mounting hardware to fit KRV20 overrun unit. **£41.15**
- 6 P00333 **40mm Eye.** Eye kit includes all mounting hardware to fit KRV20 overrun unit. **£41.15**
- 7 P00376A **Nato Eye.** Eye kit includes all mounting hardware to fit KRV20 overrun unit. **£95.00**
- 8 P00369 **Bellows.** Replacement protective bellows for drawtube of KFG and KRV20 overrun units. **£6.50**
- 9 P00937 **Damper.** Replacement hydraulic damper for KRV20. **£25.00**
- P00936 **Damper bracket.** Holds one end of the damper within the body of the overrun unit. **£5.00**
- 10 P00408 **Drawtube.** Drawtube for KFG & KRV units. **£35.00**
- 11 P00413 **Overrun lever.** Fitted to the rear of the coupling unit, this lever creates the pull on the brake rod. **£11.00**
- 12 P00901 **Energy store.** Bright plated silver coloured unit fitted until mid 2006. **£15.86**
- 13 P00868 **Spring pack.** Oil damped unit only, as fitted to later or upgraded units. **£19.68**
- 14 P00385 **Brake lever.** For KRV20 overrun units, incorporates link for breakaway cable. **£19.39**
- 15 P00363 **Clamp handle.** Jockey clamp handle. **£3.50**
- 16 P00399 **Retainer pad.** Fits within the recess in the overrun unit to securely clamp the jockey wheel. **£4.50**
- 17 P00387 **Breakaway cable spring ring type.** It is recommended that you carry a spare breakaway cable whenever you tow. **£5.90**
- 18 P00899 **Breakaway cable clevis type.** For more recent knott couplings having this type of cable fitted originally. **£5.90**



To Order – See pages 4 & 5 for distributor contact details or call direct on 0845 4082 505

To Order – See pages 4 & 5 for distributor contact details or call direct on 0845 4082 505



- 1 P0475 Jockey wheel 48mm.** Strong ribbed shaft design and heavy duty tyre suits HU12 and KFG35 overrun units or separate clamp. **£52.90**
- 2 P0475H Jockey wheel 48mm.** Heavy duty version with extended slimline handle for extra clearance against winch brackets. **£58.75**
- 3 P0474 Jockey wheel 48mm.** Medium duty smooth stem design to suit many medium sized overrun units. **£29.40**
- 4 P0476 Jockey wheel 42mm.** Standard duty smooth stem design to suit many small overrun units or separate clamp. **£27.60**
- 5 P0567 Jockey wheel for our unbraked trailer range (35mm)** **£25.85**

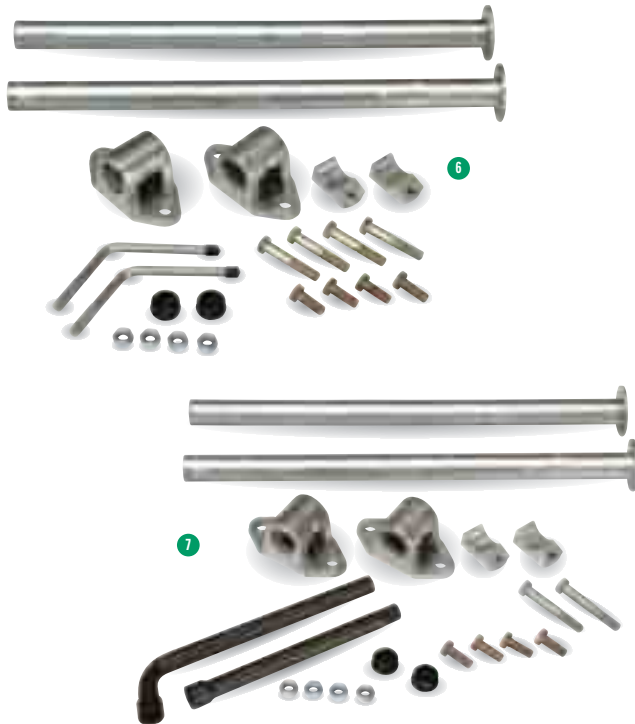

- KX0230 Propstand kit.** Pair of propstands for Maxi-plant trailers. **£58.75**
- 6 KX0221 Propstand kit.** Pair of propstands for GD, BV or Livestock models. **£35.25**
- 7 KX0222 Propstand kit.** Pair of propstands for horsebox models. **£35.25**
- KX0225 Propstand kit.** Pair of propstands for P6e models. **£35.25**
- KX0232 Propstand kit.** Pair of propstands for HB510XL. **£58.75**



- 8 P04741 Wheel.** Wheel and tyre 52mm wide x 200mm diameter. **£10.55**
- 9 P04743 R clip.** Includes chain, as fitted to P0474, P0475 & P0476. **£4.70**
- 10 P04744 Axle tube.** Fits items 3 & 4. **£1.75**
- 11 P04745 Thrust bearing unit.** Fits between inner and outer stem of jockey wheels (Item 3). **£2.50**
- 12 P04751 Wheel.** Wheel and tyre 75mm wide x 235mm diameter. **£29.40**
- 13 P04752 Wheel.** Wheel and tyre 60mm wide x 210mm diameter. **£16.15**
- 14 P04754 Jockey wheel axle.** For the wide tyre fitted to heavy duty ribbed jockey wheels. **£1.75**
- P0199 Propstand (Individual).** 508mm. **£17.50**
- P0200 Propstand (Individual).** 350mm. **£15.95**
- 15 P0209 Clamp bracket.** Complete clamp bracket for all our ribbed heavy duty jockey wheels & propstands. **£19.00**
- P0221 Propstand bracket.** Mounting bracket for 35mm propstand or jockey wheel, requires pad and handle to complete. **£5.85**
- P0221B Clamp handle.** 1/2" for imperial propstand clamps. **£4.50**
- P0221H Clamp handle.** M12 for metric propstand clamps. **£4.50**
- P0221P Retainer pad.** Fits within the recess in the P100 clamp bracket, 12mm thread. **£3.75**
- P0209SP Split pin.** Fitted through top of heavy duty prop stand. **£1.20**
- P0209H Handle.** For heavy duty prop stand clamp. **£5.00**
- P0209N Pad nut.** 5/8" square nut for the clamp pad inside the heavy duty propstand bracket. **£0.60**
- P0214 Knob.** For Bradley TJ12 Jockey wheels (originally supplied with the CU and HU series couplings). **£3.25**
- P0215 Wheel.** Wheel and tyre for P0201 and P0203. **£15.00**
- P0223 Jockey bracket.** P200 bracket for fitting 42mm diameter jockey wheels or propstand tubes. **£13.00**
- P0223P Pad.** For bracket P0223. **£5.15**
- P0206K Knob.** For Bradley jockey wheel TJ15. **£10.90**
- P0206T Thrust bearing.** For the TJ15s jockey wheel. **£5.75**
- P0206W Wheel.** Wheel and tyre for TJ15 jockey wheel. **£52.30**
- P0288 Clamp handle.** Locking handle for HU10 Overrun units or TJ15 Jockey wheel. **£7.65**



- 16 AS5875 Propstand.** The propstand used on P6e and GD84GTA models (does not include bracket - 460mm). **£10.00**
- AS5874 Propstand.** Individual propstand (560mm). **£11.50**
- P0199 Propstand (Individual).** 508mm. (With serrated shaft). **£17.50**
- P0200 Propstand (Individual).** 350mm. (With serrated shaft). **£15.95**

Couplings & Trailer Support

Bolt On Propstands

- 1 **KX0227 Propstand kit.** Pair of propstands for LT/LM models complete with pair of bolt-on spigots and full fitting kit. £58.75
- P1114 Propstand.** Individual propstand for LT/LM models (350mm tube). £29.40
- 2 **P1115/P Pin assembly.** Pin assembly for propstands on LT/LM models. £6.10
- 3 **P11170G Spigot.** Bolt on propstand spigot for LT/LM models (includes mounting hardware). £11.75

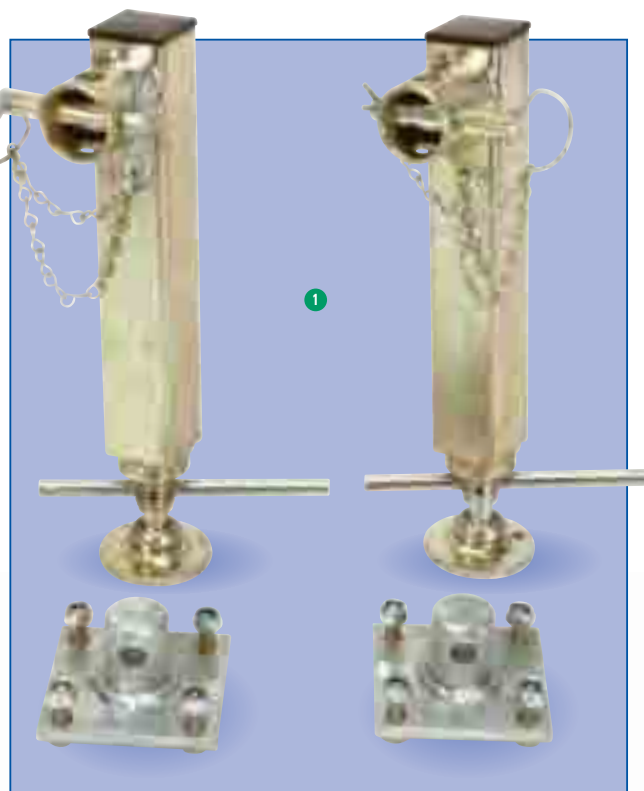
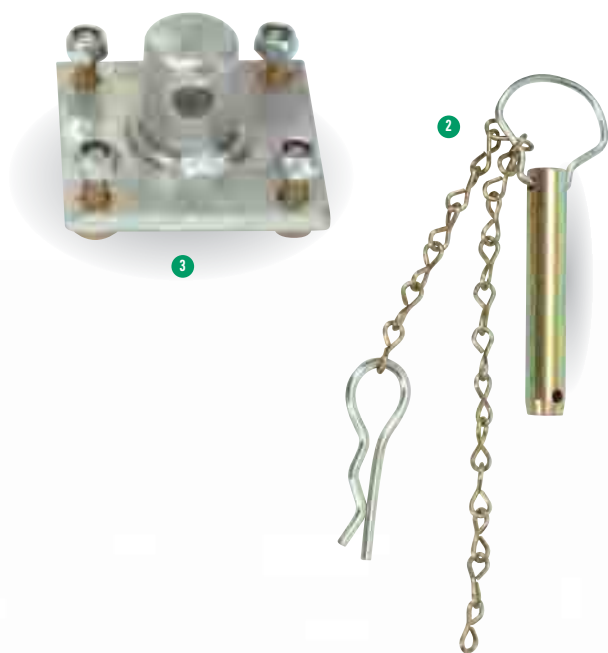

To Order – See pages 4 & 5 for distributor contact details or call direct on 0845 4082 505

LM167/B beavertail with optional electric winch, lashing rings, loading skids & propstands

To Order – See pages 4 & 5 for distributor contact details or call direct on 0845 4082 505

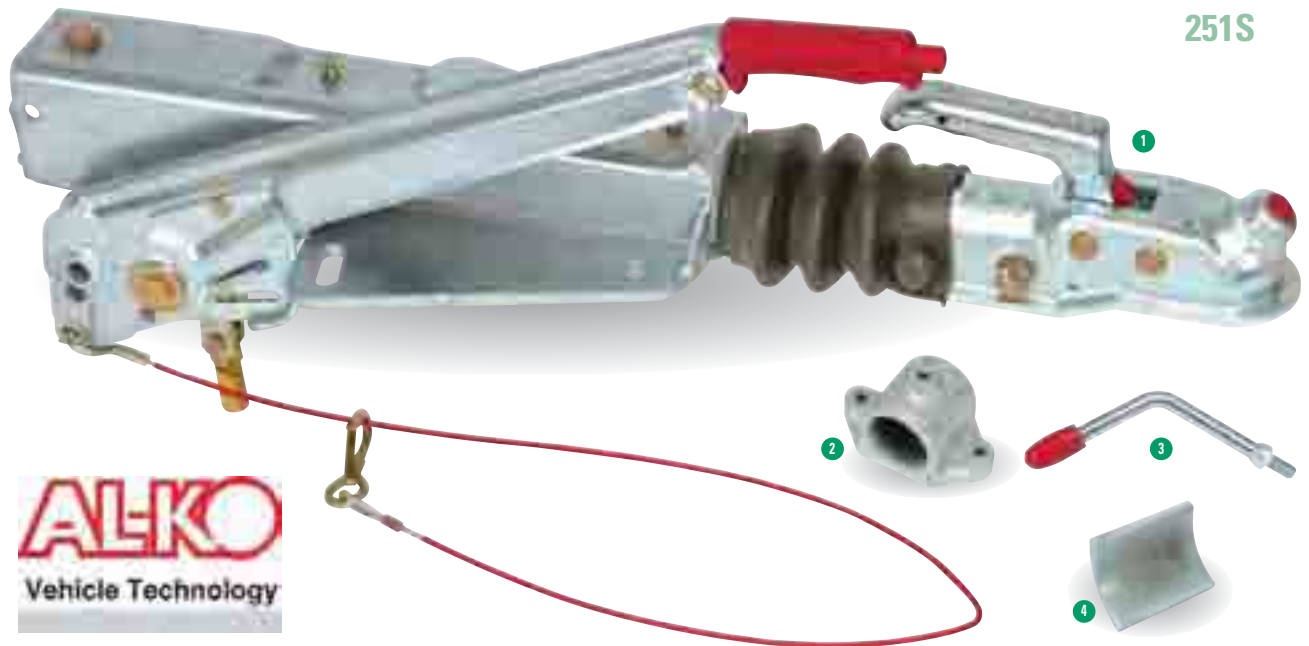

251S



1	P0515	251S Coupling unit. 1500-2600Kg GVW Hydraulically damped overrun coupling unit, incorporating gas sprung handbrake for use with autoreverse brakes and 50mm ball.	£170.40
2	P0549	Jockey Bracket. Type 295-191 this is used on the 251s overrun unit.	£16.95
3	P0549H	Clamp handle. For the 295-191 Bracket.	£7.25
4	P0549P	Pad. Fits within the recess in the 295-191 Bracket to clamp against the jockey wheel tube.	£1.50
5	P0542	Damper. Old Type. (325mm Centres).	£49.00
6	P0542A	Damper. New Type. (505mm Centres).	£43.00
7	P0528	Head. Replacement coupling head for 251's overrun unit.	£37.50
8	P0551	Bellows. For the 251s overrun unit.	£6.50
9	P0545	Brake lever. For the 251s overrun unit.	£52.00
10	P0548	Outer clamp. Outer part of Jockey wheel clamp on 251S overrun unit.	£4.00
11	P0552	Manual reverse kit. For the 251s overrun unit.	£22.30
12	P00387	Breakaway cable. It is recommended that you carry a spare breakaway cable whenever you tow.	£5.90
	P0521	Lock. Al-ko barrel lock.	£7.05
	P0554	Knob. For the Al-ko jockey wheel head.	£10.10

